

Pandora.



Spec Sheet



Official Patent and Design Numbers (either pending or granted)
Australian patent no. 2016101426

Deceivingly simple – this one's got all the bells and whistles.



**Five
At
Heart**

Pandora.



Pandora

Five At Heart

Material

Laminated MDF door (AUS: E0 MR)
(with extensive colour range)

White particle board carcass (AUS: E1 MR)

Moisture resistant base with black finish

Specification

(X) 500mm (1'8") or 600 (2') depth available

(Z) Bulk head or 30 degree slope top
(Optional)

Choice of locking system

Vented doors

TOP VIEW

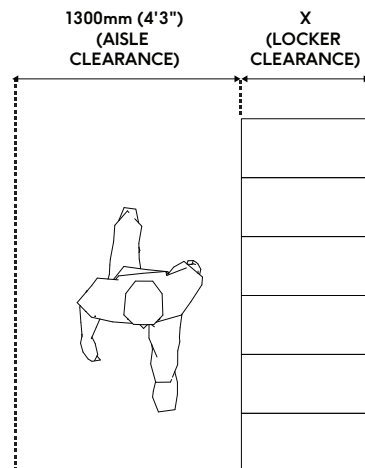

SIDE VIEW

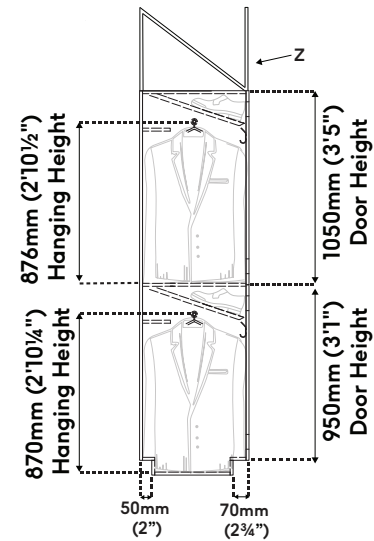

FRONT VIEW

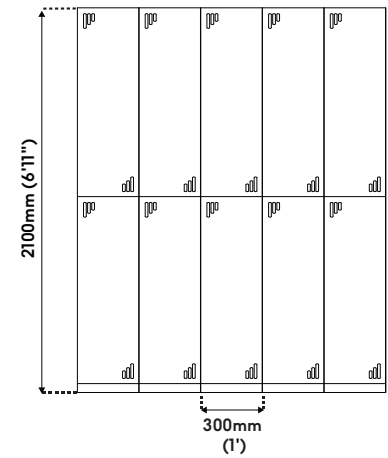

Pandora Warranty and Technical Data

Warranty Information

Five At Heart's Pandora comes with a standard 7 year warranty, effective from the handover date.

For the warranty period, we warrant that the equipment (and any materials) we supply will comply with the relevant standards at the date of installation.

This warranty is limited and may be excluded in part or in full in light of user damage or failure to install to Five At Heart specification.

We recommend a monthly visual inspection for signs of damage or need for cleaning.

Contact Five At Heart in the event of product damage.

Disclaimer

Images may differ from actual product and specifications are subject to change without prior notice.

AUS, UK, CAN: manufactured to metric dimensions.

USA: manufactured to imperial dimensions.

Installation Requirements

Lockers/auxiliary units require a minimum of 16mm (5/8") at the end of each nib wall for filler panels and 50mm (2") for corner fillers.

Maintenance Requirements

If any moving parts appear to be malfunctioning, discontinue use and contact Five At Heart.

Cleaning

For general care and maintenance, simply wipe away most spills or marks with a damp cloth, or wipe clean with non abrasive household cleaner.

Do not submerge product at any point.

Avoid scourers and abrasives as they will damage the surface.

Do not use waxes or polishing products as they dull the natural shine.

Five At Heart



fiveatheart.com

Allied Ireland | www.allied.ie
Contact Jane Delany - janedelany@allied.ie
Direct: +353 (0)86 811 6052

Creating
spaces
for however
you Roll...

allied.ie

EQA ISO 9001:2015
ISO 14001:2015
OHSAS 18001:2007

